

# CMR752

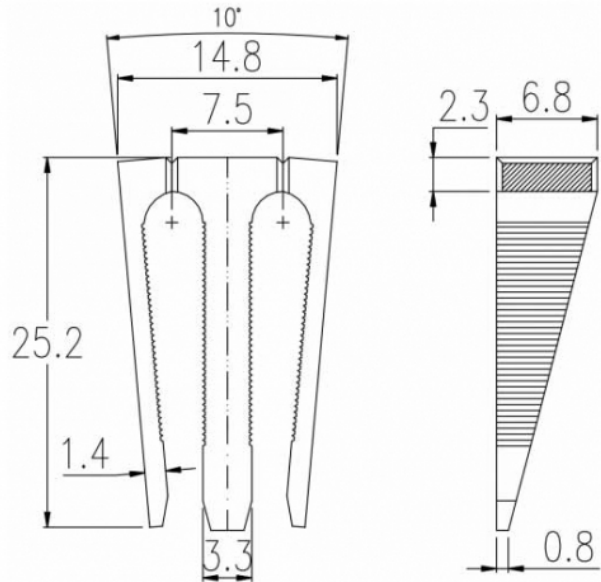

## GENERAL INFORMATION

pitch	7,5 mm
Height	-
Depth	-
Dimensional class	n/a
Wire section	-
Clamp opening size	-
Wire stripping	-
Operating temperature	-

## ELECTRICAL CHARACTERISTICS

Current	-
Voltage	-
Test Voltage	-

## MECHANICAL CHARACTERISTICS

Screw	-
Recommended torque	-

## APPROVALS DATA



Current	-	-	-
Voltage	-	-	-
Wire section	-	-	-
Torque	-	-	-
FILE	-	-	-

## MATERIALS

Housing	PA - UL 94 V0
Screw	-
Clamp	-

Terminal  
SCIP Number

-  
**Deprecated:** htmlspecialchars(): Passing null to parameter #1 (\$string) of type string is deprecated in /web/htdocs/www.euroclamp.it/home/modifica\_prodotti/modifica\_articoli.php on line 76

**COLOURS**

Standard



On request



**POLES**

01

**NAME**  
CMR752

**3D FILE**  
File available