

# ME672-7,62

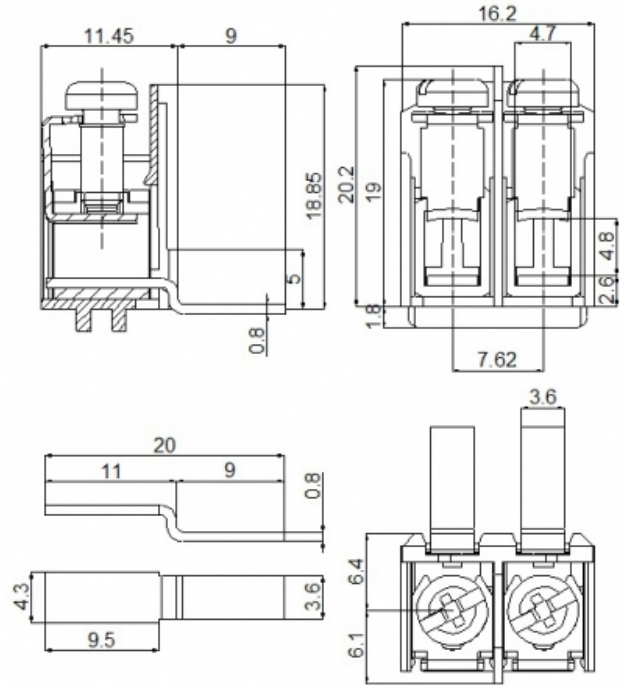

Terminals are provided not assembled to the terminal block.  
I terminali sono forniti non assemblati alla morsettiere.

## GENERAL INFORMATION

pitch	7,62 mm
Height	19 mm
Depth	12.5 mm
Dimensional class	Alta
Wire section	6.0 mm <sup>2</sup> / 10 AWG
Clamp opening size	4.7 x 4.8 mm
Wire stripping	max 8.5 mm
Operating temperature	-40 ÷ +130 °C

## ELECTRICAL CHARACTERISTICS

Current	41 A
Voltage	450 V

## MECHANICAL CHARACTERISTICS

Screw	M3.5
Recommended torque	0.8÷0.88 Nm / 7.2÷7.9 in.lbs

## APPROVALS DATA



Current	-	-	-
Voltage	-	-	-
Wire section	-	-	-
Torque	-	-	-

FILE

**MATERIALS**

Housing	PA - UL 94 V0
Screw	Galvanized steel
Clamp	-
Terminal	Tin-plated copper alloy

**COLOURS**

Standard



On request



**POLES**

01

**NAME**

ME672-7,62

**3D FILE**

File available