

MG1__-5,08-DI

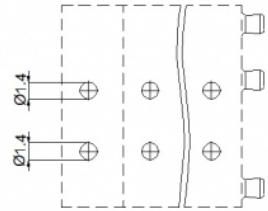
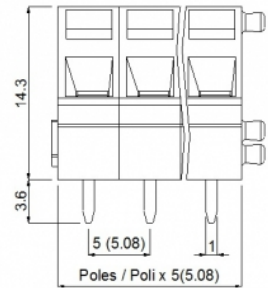
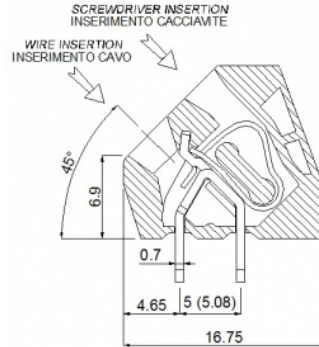

GENERAL INFORMATION

pitch	5,08 mm
Height	14.3 mm
Depth	16.75 mm
Dimensional class	Bassa
Wire section	2.5 mm ² / 14 AWG
Clamp opening size	2.45 x 2.45 mm
Wire stripping	max 9 mm
Operating temperature	-40 ÷ +130 °C

ELECTRICAL CHARACTERISTICS

Current	24 A
Voltage	250 V
impulse voltage	2 kV

MECHANICAL CHARACTERISTICS

Screw	-
Recommended torque	-

APPROVALS DATA



Current	-	-	UL 1059
Voltage	-	-	17 A factory / 17 A field
Wire section	-	-	300 V
Torque	-	-	12 AWG
FILE	-	-	-
			E178356

MATERIALS

Housing	PA - UL 94 V0
Screw	-

Spring
Terminal

Spring steel
Tin-plated copper alloy

COLOURS

Standard



On request



POLES

01

NAME

MG101-5,08-DI

3D FILE

File not available for this product