

# MVS15\_-10-IT

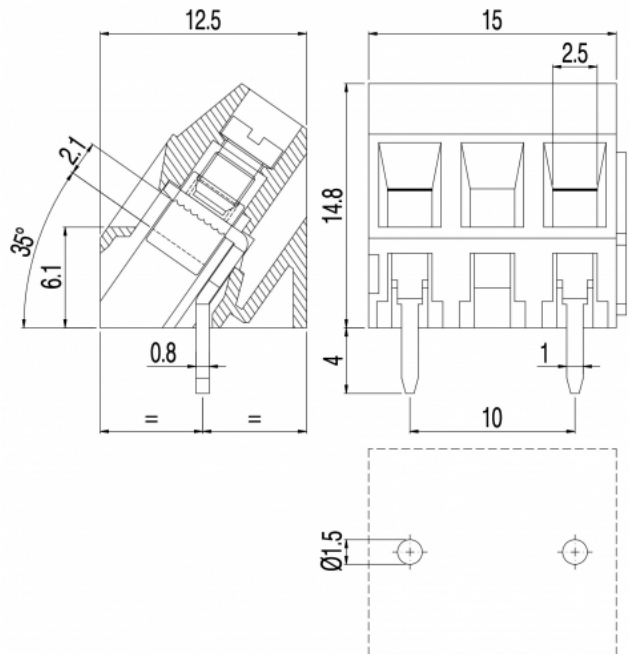

**GENERAL INFORMATION**

pitch	10 mm
Height	14.8 mm
Depth	12.5 mm
Dimensional class	Bassa
Wire section	1.5 mm <sup>2</sup> / 16 AWG
Clamp opening size	2.5 x 2.1 mm
Wire stripping	max 7 mm
Operating temperature	-40 ÷ +130 °C

**ELECTRICAL CHARACTERISTICS**

Current	17.5 A
Voltage	750 V
Test Voltage	3 kVrms/60s

**MECHANICAL CHARACTERISTICS**

Screw	M3
Recommended torque	0.5÷0.55 Nm / 4.5÷4.9 in.lbs

**APPROVALS DATA**



	<b>EN 60998-1</b>		<b>UL 1059</b>
Current	17.5 A	-	17.5 A factory / 10 A field
Voltage	750 V	-	600 V
Wire section	1.5 mm <sup>2</sup>	-	16 ÷ 30 AWG
Torque	0.5 Nm	-	4.5 Lb-in
FILE	CA02.00598	-	E178356

**MATERIALS**

Housing	PA - UL 94 V0
Screw	Galvanized steel

Clamp  
Terminal  
SCIP Number  
**COLOURS**

Nickel-plated copper alloy  
Tin-plated copper alloy  
713ad43e-8dff-4607-9cfa-843d4a730153

Standard



On request



**POLES**

- 1
- 2

**NAME**

- MVS151-10-IT
- MVS152-10-IT

**3D FILE**

- File available
- File available