

MVST25_-5-W

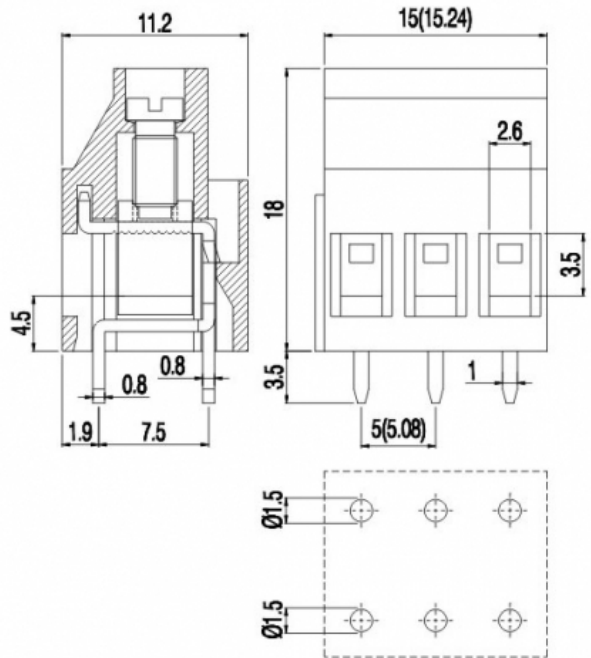
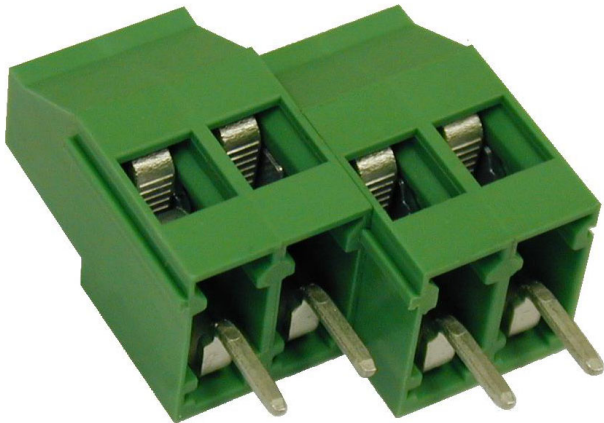

GENERAL INFORMATION

pitch	5 mm
Height	18 mm
Depth	11.2 mm
Dimensional class	Media
Wire section	2.5 mm ² / 14 AWG
Clamp opening size	2.8 x 3.5 mm
Wire stripping	max 9 mm
Operating temperature	-40 ÷ +105 °C

ELECTRICAL CHARACTERISTICS

Current	24 A
Voltage	250 V
impulse voltage	2 kV

MECHANICAL CHARACTERISTICS

Screw	M2.5
Recommended torque	0.4÷0.44 Nm / 3.5÷3.9 in.lbs

APPROVALS DATA



Current	-	-	20 A factory / - A field
Voltage	-	-	300 V
Wire section	-	-	12 AWG
Torque	-	-	3.5 Lb-in
FILE	-	-	E178356

MATERIALS

UL 1059

Housing
Screw
Clamp
Terminal

PA - UL 94 V0
Galvanized steel
Nickel-plated copper alloy
Tin-plated copper alloy

COLOURS

Standard



On request

POLES

2
3

NAME

MVST252-5-W
MVST253-5-W

3D FILE

File not available for this product
File not available for this product