

# PVS\_\_-5

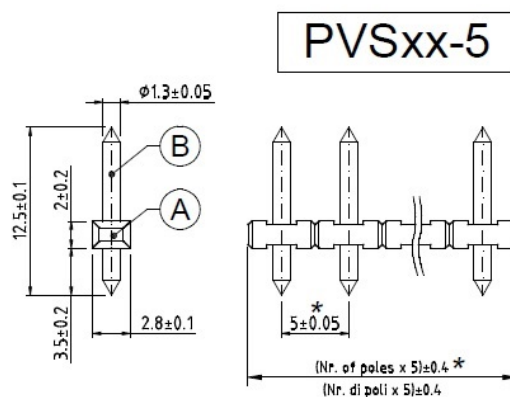
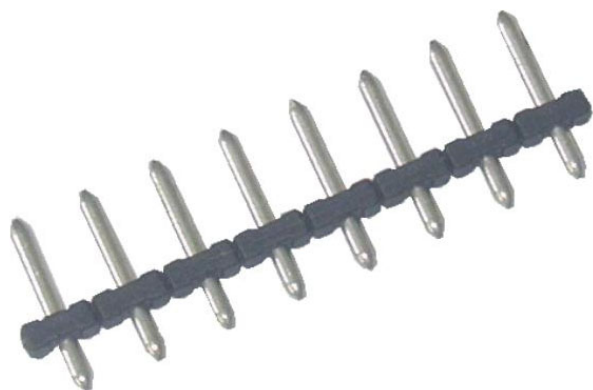

\* Dimension and tolerance are valid only for PCB soldering side  
 Quota e tolleranza valide soltanto per il lato del CS a saldare

### GENERAL INFORMATION

pitch	5 mm
Height	12.5 mm
Depth	2.8 mm
Dimensional class	Bassa
Wire section	-
Clamp opening size	-
Wire stripping	-
Operating temperature	-40 ÷ +130 °C

### ELECTRICAL CHARACTERISTICS

Current	10 A
Voltage	250 V
Test Voltage	4 kVrms/60s

### MECHANICAL CHARACTERISTICS

Screw	-
Recommended torque	-

### APPROVALS DATA



Current	-	EN 61984	UL 1059
Voltage	-	max. 20 A	18 A factory / 15 A field
Wire section	-	250 V	300 V
Torque	-	-	-
FILE	-	40053107	E178356

### MATERIALS

Housing	PA - UL 94 V0
Screw	-
Clamp	-
Terminal	Tin-plated copper alloy
SCIP Number	e7871ea5-2cf8-4f17-b626-38a85b04faba

### COLOURS

Standard



On request

**POLES**

02  
03  
04  
05  
06  
07  
08  
09  
10  
11  
12  
13  
14  
15  
16  
17  
18  
19  
20  
21  
22  
23  
24

**NAME**

PVS02-5  
PVS03-5  
PVS04-5  
PVS05-5  
PVS06-5  
PVS07-5  
PVS08-5  
PVS09-5  
PVS10-5  
PVS11-5  
PVS12-5  
PVS13-5  
PVS14-5  
PVS15-5  
PVS16-5  
PVS17-5  
PVS18-5  
PVS19-5  
PVS20-5  
PVS21-5  
PVS22-5  
PVS23-5  
PVS24-5

**3D FILE**

File available  
File available  
File available  
File available  
File available  
File available  
File available  
File available  
File available  
File available  
File available  
File available  
File available  
File available  
File available  
File available  
File available  
File available  
File available  
File available  
File available  
File available  
File available  
File available