

PDV__-3,81-H-M

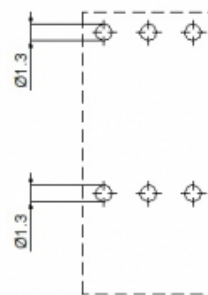
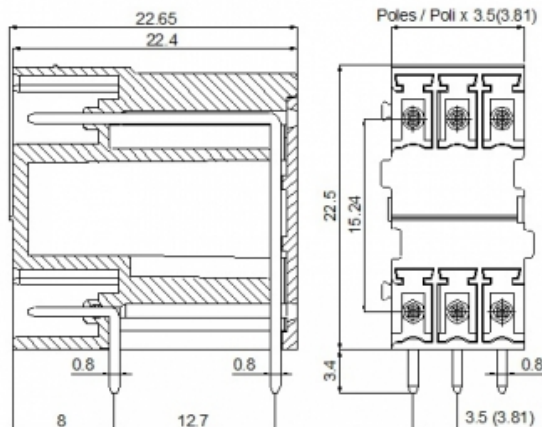
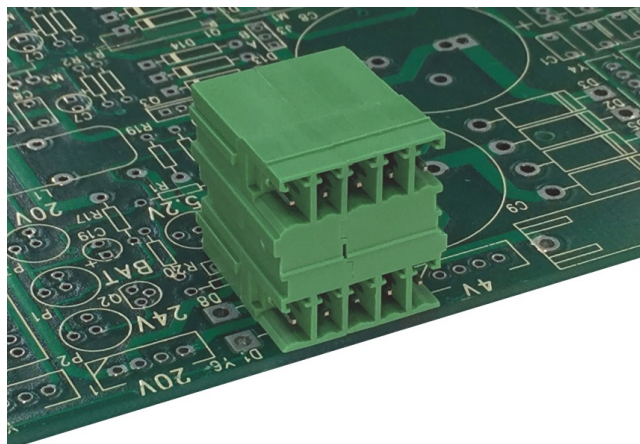

GENERAL INFORMATION

pitch	3,81 mm
Height	22.65 mm
Depth	22.5 mm
Dimensional class	Media
Wire section	-
Clamp opening size	-
Wire stripping	-
Operating temperature	-40 ÷ +130 °C

ELECTRICAL CHARACTERISTICS

Current	11 A
Voltage	160 V
Test Voltage	2.5 kVrms/60s

MECHANICAL CHARACTERISTICS

Screw	-
Recommended torque	-

APPROVALS DATA



Current	-	8 A	11 A factory / 11 A field
Voltage	-	160 V	300 V
Wire section	-	-	-

Torque - - -
FILE - 40048261 E178356

MATERIALS

Housing PA - UL 94 V0
Screw -
Clamp -
Terminal Tin-plated copper alloy

COLOURS

Standard



On request



POLES

02
03

NAME

PDV02-3,81-H-M
PDV03-3,81-H-M

3D FILE

File not available for this product
File not available for this product